



Dewhurst US96 Compact 2 Pushbutton

The US96 Braille Pushbutton meets all the requirements of the visually impaired. The wide tactile legend can be easily seen from all angles and can be illuminated in a variety of colours. The Braille dots below the legend are Standard English Braille. The pressel background can be either black, providing good contrast with legend and faceplate, or stainless steel. The US96 is available with the standard Compact 2 body or Compact 3, a useful option for surface mount fixturs.

Features & Benefits

- 15mm tactile legend with Braille
- A halo of light between the pressel and surround via a patented hidden recess encircles the pressel and illuminates the legend
- Legend & halo can be constantly illuminated at half intensity, switching to full intensity for indication of position or call acceptance
- Large range of pressel legends
- Matching range includes keyswitches, rocker switches and indicators
- Also available with C3 body
- Vandal resistant with stainless steel front
- Meets EN81-1/2, EN81-71 (Category 2), EN81-72, EN81-73, EN60529 (IP54), AS1735 Part12 with H/C surround & dual illumination



Illumination, Finishes & Marking

- Wide range of colours for illumination including (non), red, yellow, green, blue and white
- Range of pressel finishes including brushed stainless, mirror stainless, brushed brass and mirror brass*
- Range of surround finishes and heights - chrome, brass, black - 3.2 and 4.8mm
- Single, dual and bicolour illumination
- A large range of legends in Helvetica Medium characters & symbols are available
- 15mm high, tactile, grey characters/symbols are formed during the moulding of the pressel. Standard English Braille appears below the characters/symbols.

* Standard pressels are a brushed stainless steel plate moulded with red or grey polycarbonate



Dimensions

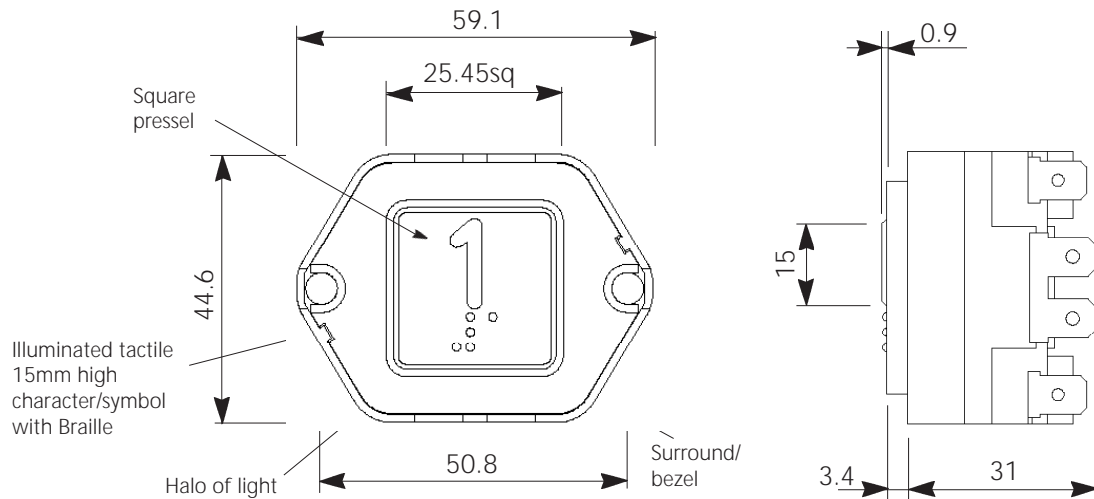

Compact 2 Pushbuttons can be supplied loose or incorporated into stations with 1.5mm or 2.5mm stainless steel faceplates, with a vertical pitch of 50mm and horizontal pitch of 60mm i.e the pushbutton body can be rotated through 90 degrees (horizontal version shown above). If pushbuttons are supplied loose, spacers are provided to accommodate the differing faceplate thickness.

Technical Details

Weight:	70grms	
Moulded in:	High grade polycarbonate	
Pressel plate material:	Brushed 304 stainless (standard)	
Pressel plate area:	620mm ²	
Button force:	3.5N	
Pushbutton size:	59.1mm w x 44.6mm h x 32.0mm d	
Pressel size:	24.2mm w x 24.2mm h x 3.2mm d	
Legend size:	15mm high, Helvetica medium characters	
LED current:	20mA (typically)	
LED voltage:	12/24/30/48/110V a.c./d.c. ±15%	
Operation:	Wiping action, slow make and break with solid silver contacts	
Ratings:	10 amps max	
	240V a.c. at 3.0 amps max. resistive loads	- min. no. of operations: 1 x 10 ⁶
	240V d.c. at 0.5 amps max. resistive loads	- min. no. of operations: 2 x 10 ⁶
	110V d.c. at 100mA max. inductive TC40ms	- min. no. of operations: 1 x 10 ⁶
	12V d.c. at 5mA max. resistive loads	- min. no. of operations: 10 x 10 ⁶
Contact arrangements:	2 N/O, 2 N/C or 1 N/O + 1 N/C	Please note that it is possible for the N/O contact to make before the N/C contact has opened on the 1 N/O + 1 N/C configuration
Code compliance:	Meets EN81-1/2, EN81-71(Category 2), EN81-72, EN81-73	
IP Rating:	EN60529 (IP54)	

Cutouts & Stud Positions

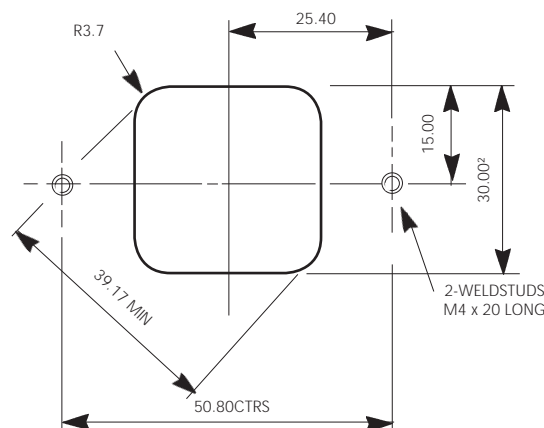

Cleaning your US96 Pushbutton

Many **Dewhurst** lift products are made of **polycarbonate** (Using GE's **Lexan®** or Bayer's **Makrolon®**).

The US96 is highly durable and vandal resistant but the plastic parts can be damaged by aggressive cleaning agents, Dewhurst therefore recommends:



Clean the part with a **cotton cloth and warm water** before applying the cleaning product



Use **PH-neutral or slightly acid cleaning products only** (including aromatised ones) Ethylic alcohol, isopropyl alcohol or ethylene glycol based multipurpose cleaning products and dish soaps are suggested.



Dilute the cleaning product in warm water and apply using a wet cotton cloth.



Grease, glue and paint may be removed with ethylic alcohol or isopropyl alcohol.

Recommended Cleaning Products (*):

Europe	North America
Windus - Brial Top - Ecolab Mr. Proper Surfaces Delicates - Proctor & Gamble Palmolive, Colgate Palmolive	Formula 409® Cleaner Degreaser Joy®, Proctor & Gamble Windex, Drackett Products Palmolive, Colgate Palmolive

(*): *Due to the vast number of cleaning products available on the market, the list of recommended products above is an illustration only*

Note:

- Do not use abrasive cleaning agents
- Do not use sharp tools to remove dirt (chewing gum, glue, etc.)
- Do not use solvents based with Ketones, benzene, methanol, toluene (also known as methylbenzene or phenyl methane) or alkaline and ammonia based cleaning agents
- Do not use cleaning agents at high temperatures
- Do not leave cleaning agents on the parts for long periods: remove immediately after cleaning using a wet cotton cloth and warm water
- Do not use dry cotton cloths and sponges